

# APstorage Sea Family ELT Series PCS Installation & User Manual

(For EMEA)



## Table of Contents

<b>1. Important Safety Instructions</b> .....	2
1.1 Safety Instructions .....	2
1.2 Radio Interference Statement .....	3
1.3 Communication Disclaimer .....	3
1.4 Symbols replace words on the equipment, on a display, or in manuals .....	4
<b>2. Product Introduction</b> .....	5
2.1 Features .....	5
2.2 Basic System Architecture .....	6
2.3 Back-up Load Configuration .....	8
2.4 Casing Introduction .....	9
2.5 LED .....	10
<b>3. Installation</b> .....	11
3.1 Packing List .....	11
3.2 Select Mounting Location .....	12
3.3 PCS installed on the wall .....	13
3.4 Terminals and Cables Introduction .....	14
3.5 Interface Layout Introduction .....	16
3.6 Battery Connection .....	17
3.7 AC Wiring Connection .....	17
3.8 Ground Wiring Connection .....	18
3.9 Communication Connection .....	18
3.10 DO Connection .....	18
3.11 CT Connection .....	19
3.12 AP Dongle .....	20
3.13 ATS Wiring Connection .....	20
3.14 Wiring System for PCS .....	21
3.15 PCS Operation Procedures .....	24
<b>4. Off-Grid AC Coupling Installation</b> .....	25
4.1 Frequency Shift Power Control .....	25
4.2 PV System to APstorage Pairing .....	26
<b>5. User Interface</b> .....	27
5.1 Configure APstorage with EMA Manager .....	27
5.2 Home Page .....	29
5.3 Workbench .....	31
5.4 Settings .....	38
<b>6. Technical Data</b> .....	39
EU DECLARATION OF CONFORMITY .....	41
EU-KONFORMITÄTSERKLÄRUNG .....	42

## 1. Important Safety Instructions

This manual contains important instructions to be followed during installation and maintenance of the APstorage PCS. To reduce the risk of electrical shock and ensure the safe installation and operation of the APstorage PCS, the following symbols appear throughout this document to indicate dangerous conditions and important safety instructions.

### **DANGER:**

This indicates a hazardous situation, which if not avoided, will result in death or serious injury.

### **WARNING:**

This indicates a situation where failure to follow instructions may be a safety hazard or cause equipment malfunction. Use extreme caution and follow instructions carefully.

### **NOTE:**

This indicates information that is very important for optimal system operation. Follow instructions closely.

### 1.1 Safety Instructions

**IMPORTANT SAFETY INSTRUCTIONS. SAVE THESE INSTRUCTIONS.** This guide contains important instructions that you must follow during installation and maintenance of the PCS. Failing to follow any of these instructions may void the warranty. Follow all of the instructions in this manual. These instructions are key to the installation and maintenance of the APstorage PCS. These instructions are not meant to be a complete explanation of how to design and install APstorage PCSs. All installations must comply with national and local electrical codes and standards.

### **DANGER:**

- Only qualified professionals should install and/or replace the APstorage PCS.
- Perform all electrical installations in accordance with local codes.
- To reduce risk of burns, do not touch the body of the PCS.

### **WARNING:**

- Do **NOT** attempt to repair the APstorage PCS. If it shows abnormal performance, Contact APsystems Customer Support to obtain adequate support. Damaging or opening the APstorage PCS will void the warranty.
- These servicing instructions are for use by qualified personnel only. To reduce the risk of electric shock, do not perform any servicing other than that specified in the operating instructions".

**NOTE:**

Before installing or using the APstorage PCS, please read all instructions and cautionary markings in the technical documents and on the APstorage PCS.

**1.2 Radio Interference Statement**

This equipment could radiate radio frequency energy which might cause interference to radio communications if you do not follow the instructions when installing and using the equipment. But there is no guarantee that interference will not occur in a particular installation. If this equipment causes interference to radio or television reception, the following measures might resolve the issues:

- A) Relocate the receiving antenna and keep it well away from the equipment.
- B) Consult the dealer or an experienced radio / TV technician for help.

Changes or modifications not expressly approved by the party responsible for compliance may void the user's authority to operate the equipment.

**1.3 Communication Disclaimer**

The EMA system provides a friendly interface to monitor the working status of the whole energy storage system. At the same time, it can also help to locate problems during system maintenance. If communication has been lost for more than 24 hours, please contact the technical support of APsystems.

## 1.4 Symbols replace words on the equipment, on a display, or in manuals

The following types of safety precautions and general information symbols used in this manual must be followed during the installation, operation and maintenance of the PCS.



Caution, risk of electric shock.



Caution, hot surface.



NOTICE, danger! This device directly connected with electricity generators and public grid.



After the inverter is turned off, wait for at least 5 minutes before opening the PCS or touching live parts.



Refer to the operating instructions.



Products shall not be disposed as household waste.



CE mark.

### Qualified personnel

Person adequately advised or supervised by an electrically skilled person to enable him or her to perceive risks and to avoid hazards which electricity can create. For the purpose of the safety information of this manual, a "qualified person" is someone who is familiar with requirements for safety, electrical system and EMC and is authorized to energize, ground, and tag equipment, systems, and circuits in accordance with established safety procedures. The inverter and storage system may only be commissioned and operated by qualified personnel.

## 2. Product Introduction

APstorage introduces its 1st generation of smart Power Conversion Systems with the ELT series products, the three-phase AC coupled Low Voltage battery inverter solution for residential PV applications.

With automatic energy management features based on intelligent software and integrated monitoring, system owners can choose between multiple energy control modes including back-up power supply, self-consumption, advanced and peak-shaving modes to secure critical loads during power outages, maximize energy savings and optimize electricity bills.

### 2.1 Features

#### Performance

- ▶ Nominal power rating up to 12000VA
- ▶ Peak backup power up to 18000VA
- ▶ Max efficiency up to 96.5%

#### Safety

- ▶ Ingress protection IP65
- ▶ 48V low battery voltage input
- ▶ Intelligent charging technology, protecting battery life
- ▶ High and low voltage isolation topologies, ensuring personal safety

#### Flexible

- ▶ Compatible with multiple battery brands
- ▶ Allow generator to act as grid power source
- ▶ Support Off-grid PV function
- ▶ AC-Coupled solution for new or existing installations

#### Intelligent

- ▶ Support 100% three-phase unbalanced output
- ▶ UPS-level switching time <10ms
- ▶ Innovative multiple energy control modes: Backup power supply, Self-consumption, Peak and valley, and Peak shaving
- ▶ 24-hour intelligent energy management system
- ▶ Intelligent operation and maintenance platform with EMA

## 2.2 Basic System Architecture

A typical APstorage system includes Two main elements:

- APstorage PCS, which is a smart battery Power Conversion System.

ELT Series PCS is a 3-phase Low Voltage Battery inverter for residential storage.

- A compatible Battery pack (see battery compatibility list)

### Option 1 : PV system working Off-Grid

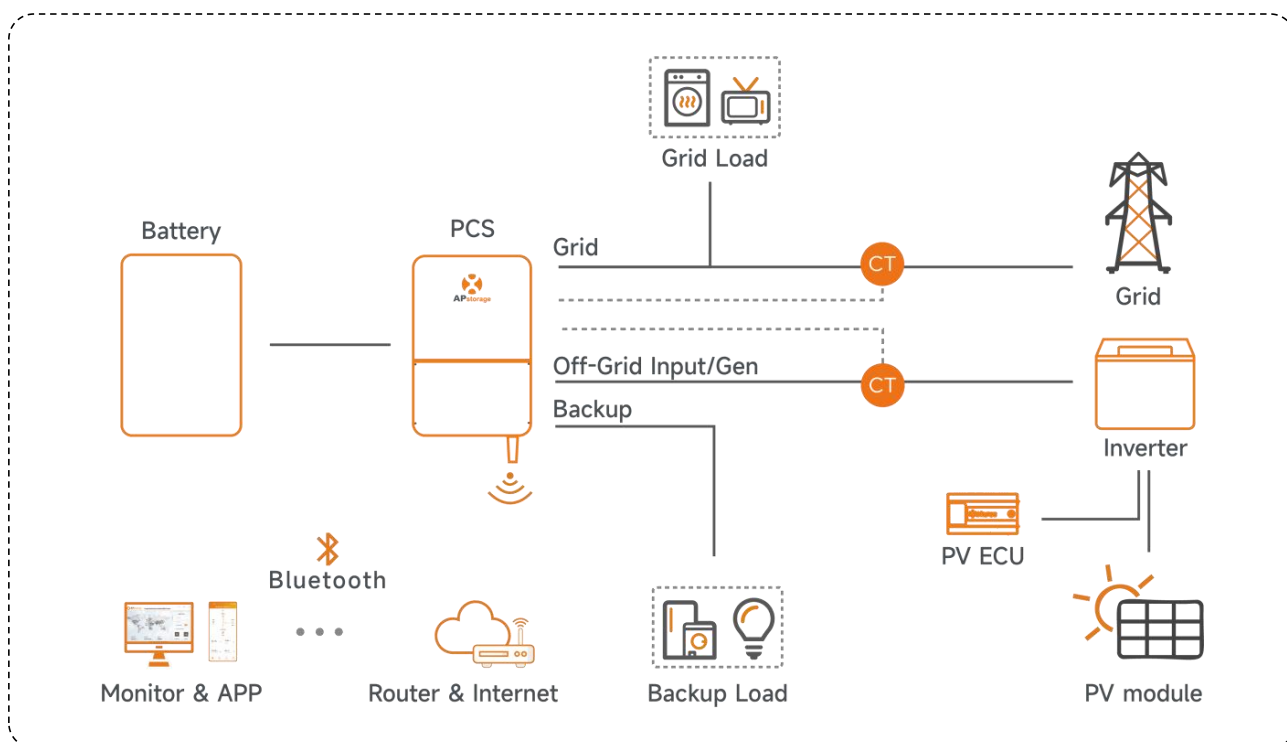

In option 1, Off grid function only compatible with APsystems QT2 microinverters (fully compatible).

#### NOTE:

If the wireless signal in the area where the PCS is weak, it is necessary to add a Wi-Fi signal booster at a suitable place between the router and the PCS.

### Option 2 : PV system not working off-grid

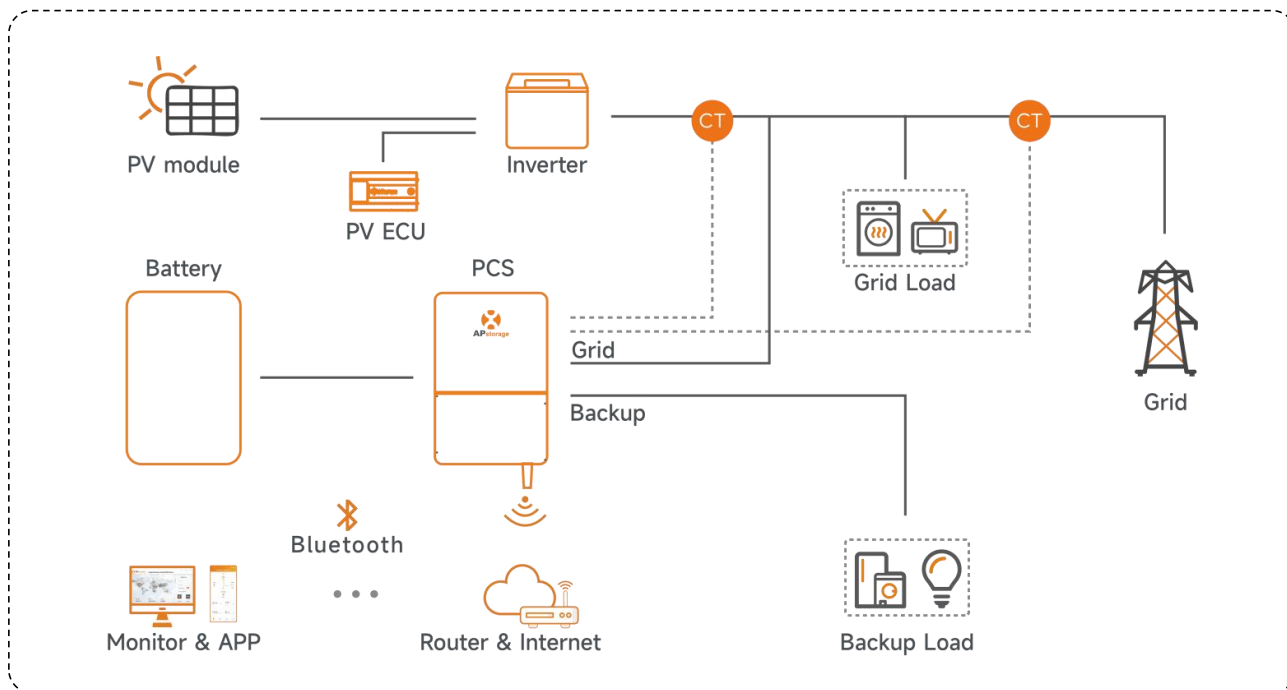

### Option 3 : Mix of option 1 and 2 following the conditions above

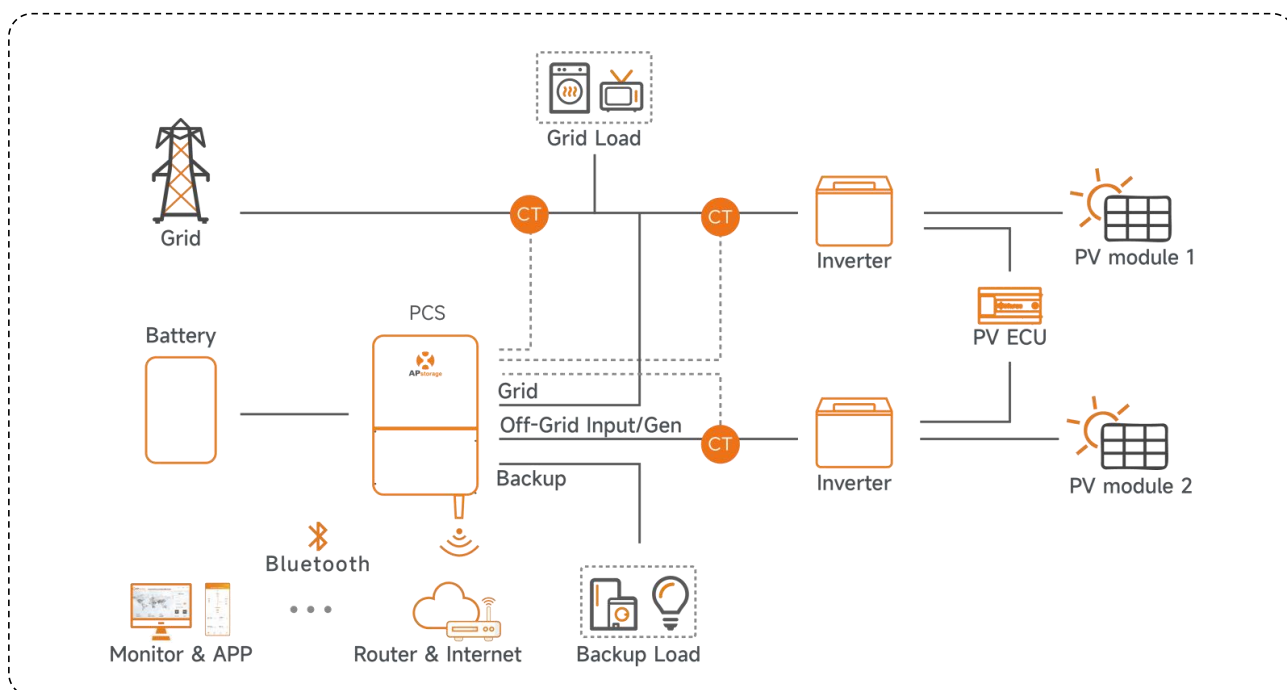

**NOTE:**

In a Storage System with APStorage PCS, the battery is one of the key components. Therefore, it is necessary to keep the installation environment well ventilated, please refer to Battery user manual.

## 2.3 Back-up Load Configuration

Case1. If it is a three-phase load, then the total power of the three-phase load does not exceed 12kVA.

Case2. If it is a single-phase load, the power of each phase load does not exceed 4kVA.

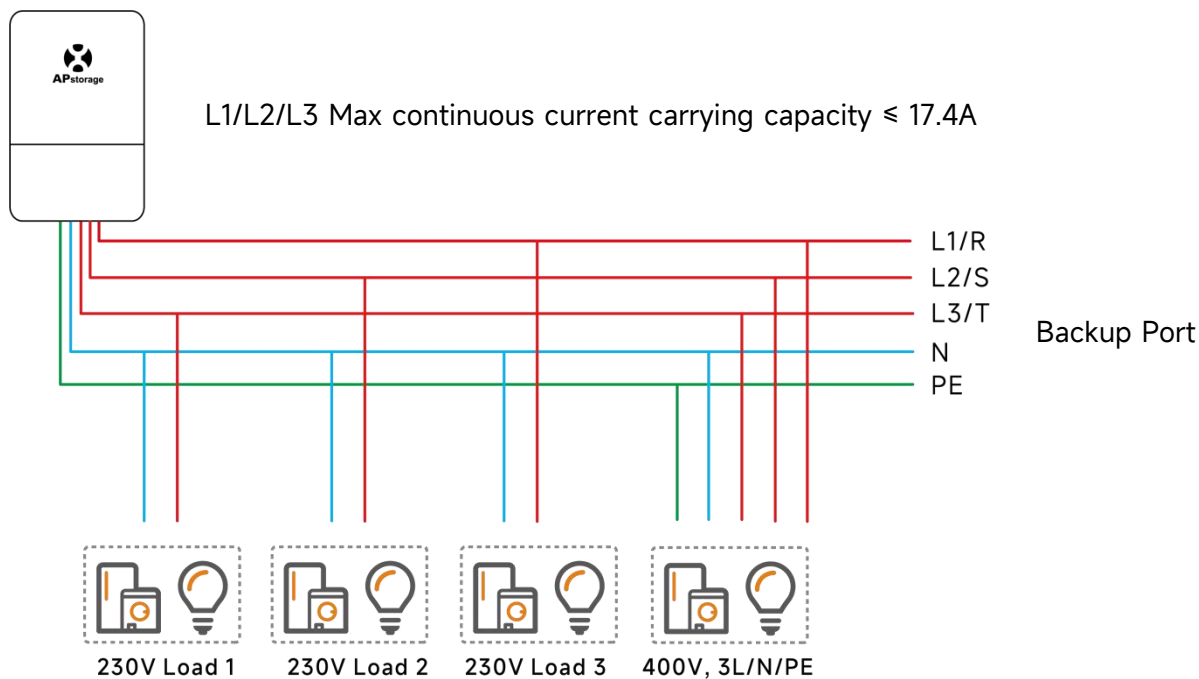

### NOTE:

The specified single-phase load received by L1N, L2N, and L3N does not exceed 4kW. If there is a three-phase load, the power of the single-phase load needs to be subtracted and evenly distributed. For example, if the maximum single-phase load on L1N, L2N, and L3N is 2kVA each, then the maximum three-phase load is 6kVA.

- L1N: voltage between L1 and Neutral line
- L2N: voltage between L2 and Neutral line
- L3N: voltage between L3 and Neutral line

## 2.4 Casing Introduction

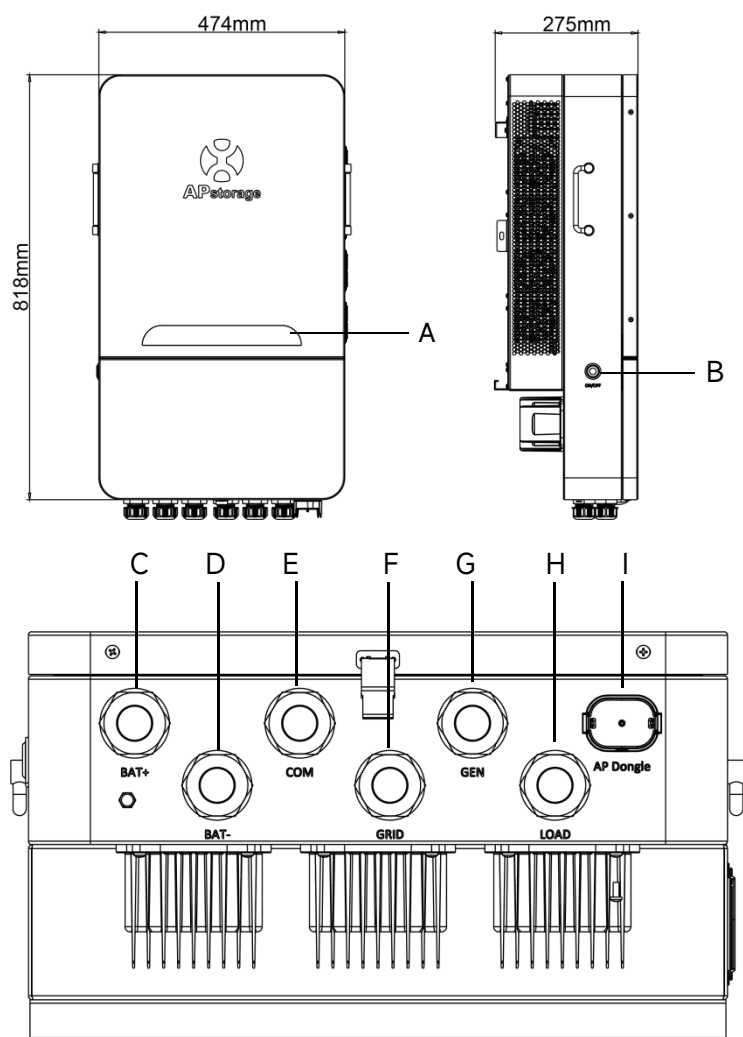

Once the PCS has been properly installed and the batteries are connected well, simply press On/Off button (located on the left side of the case) to turn on the PCS and press On/Off button(ON/OFF button is switched off) to turn off the PCS.

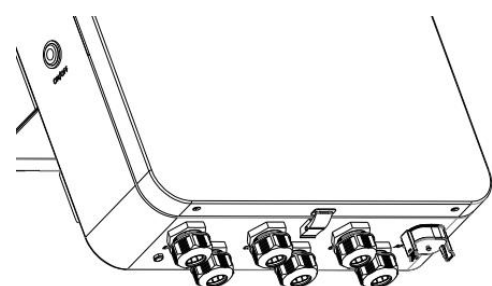

\* The image shown here is for reference only. The actual product received may differ.

Object	Name	Description
A	LED	LED indicators
B	On/Off Button	Turn on/off the PCS
C	BAT+	Battery positive cable inlet
D	BAT-	Battery negative cable inlet
E	COM	Communication cables inlet
F	GRID	AC Grid cables inlet
G	GEN	Generator cables inlet
H	LOAD	Backup Load cables inlet
I	AP Dongle	AP Dongle insertion port

## 2.5 LED

There are eight LED indicators on the PCS unit, indicating the working state of the PCS.



LED	Condition	Description
SYSTEM		The system is operating
		The system is starting up
		The system shutdown
GRID		The grid exists and is connected
		The grid exists but is not connected
		The grid does not exist
BACK UP		The backup system is operating
		The backup is off
ENERGY		Buy energy from grid
		Zero output
		Supplying energy to grid
		The grid is not connected or system is not operating
BATTERY		The battery is charging
		The battery is discharging
		The battery SOC is low
		The battery is disconnected
WI-FI		The WiFi is connected to the router
		The WiFi is not connected to the router
		The WiFi function is closed
COM		The battery and the internet communication are normal
		The battery communication is normal,
		The battery communication is abnormal,
		The battery and the internet communication are abnormal
FAULT		Fault has occurred
		Back up output overload
		No fault

: Light on

: Light off

: Every 5 seconds light on for 1 second.

: Every 2 seconds light on for 1 second.

## 3. Installation

### 3.1 Packing List

Check the equipment before installation. Please make sure nothing is damaged in the package. You should have received the items in the following package:

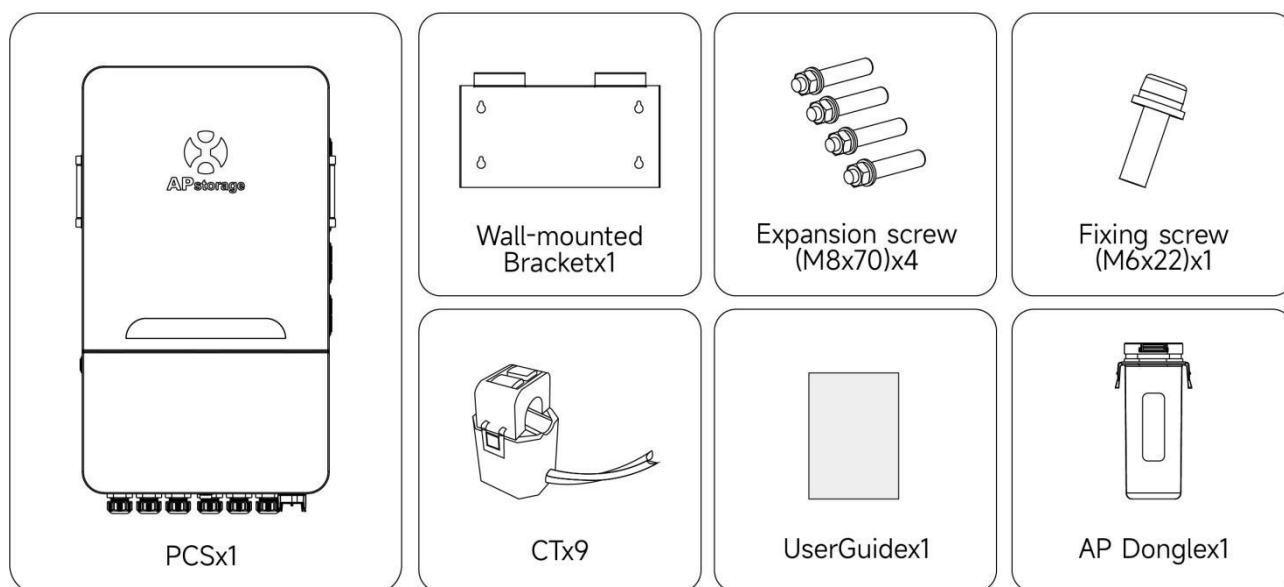

#### NOTE:

The expansion screws are applicable only to cement concrete walls. For other types of walls, install expansion screws based on the wall type.

#### NOTE:

The customer will need to purchase a combiner box for parallel connection of the batteries. Combiner box requirements: rated current of each connector  $\geq 100A$ .

### 3.2 Select Mounting Location

1. PCS should be installed on a solid surface, where is suitable for PCS's dimensions and weight.
2. Do not install PCS in a confined space with no ventilation.
3. If the PCS is installed outside, it should be protected under shelter from direct sunlight or bad weather conditions (like snow, rain, lightning, etc). Fully shielded installation locations are preferred.

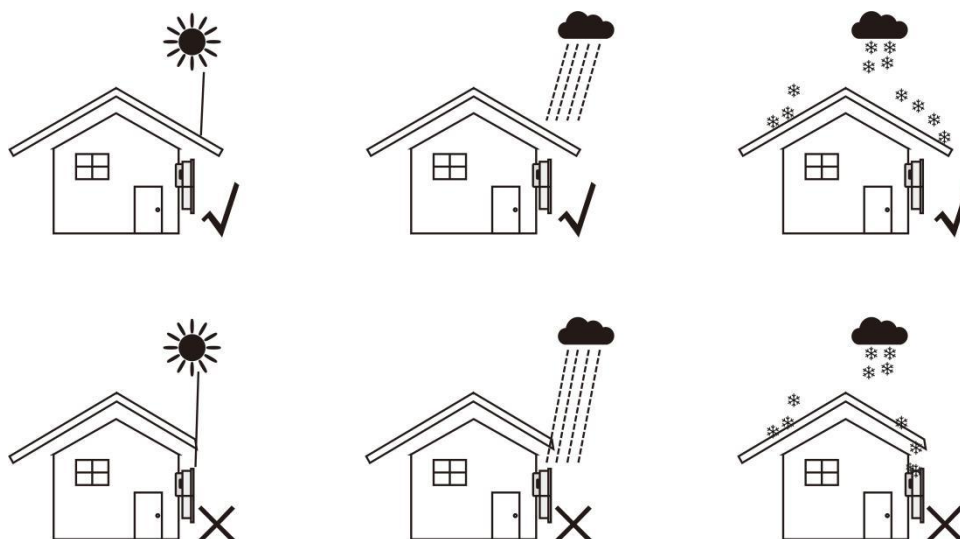

4. Install the PCS vertically on the wall.
5. Make sure that the PCS is mounted “face-up”: Product logo is visible after installation.
6. Leave enough space around PCS. The specific requirements are as follows:

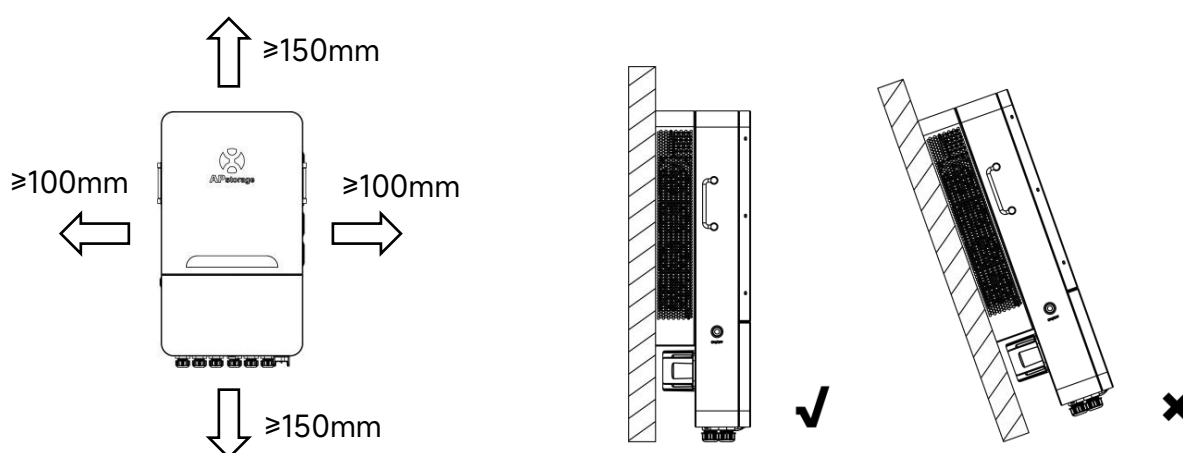

#### WARNING:

This indicates a situation where failure to follow instructions may be a safety hazard or cause equipment malfunction. Use extreme caution and follow instructions carefully.

### 3.3 PCS installed on the wall

#### STEP 1

Mark the holes position on the wall and drill holes according to wall type and expansion screws type. The configured expansion screw is drilled with a diameter of 12mm(0.5") and a depth of 50-55mm(1.9-2.2").

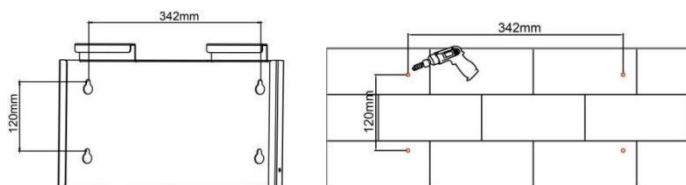

#### STEP 2

1. Put the expansion screws into the holes on the wall. Use a wrench to tighten the hex nuts, so that the expansion screws sleeve are fully expanded.

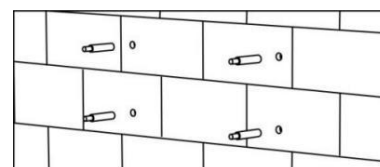

2. Then remove the hex nuts. Hang the wall mounting bracket into the expansion screws, and use the hex nuts to fix it firmly.

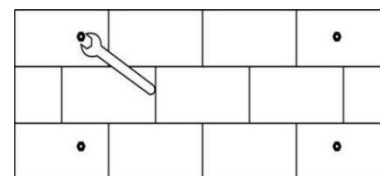

3. Make sure that the wall mounting bracket is horizontal after installation.

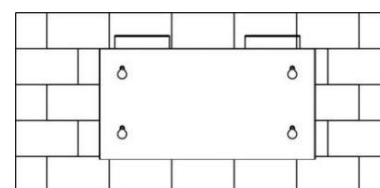

#### STEP 3

Lift the PCS to hang it into the wall mounting bracket, and fix the PCS on wall mounting bracket with the M6×22mm screw.

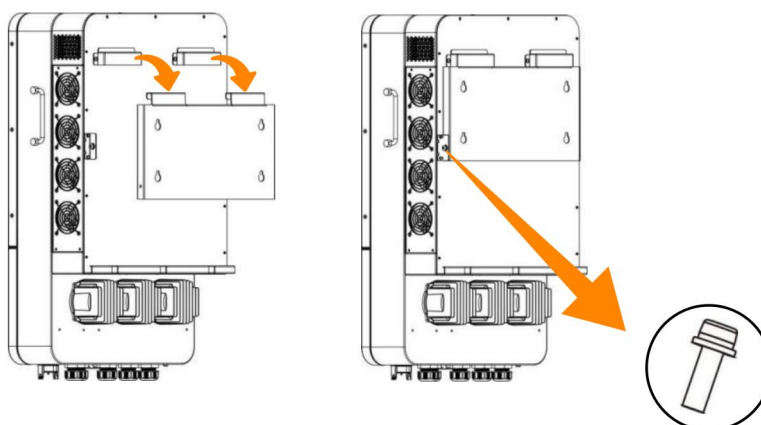

M6×22mm Screw

### 3.4 Terminals and Cables Introduction

When wiring, you need to crimp appropriate terminals on the cable (as shown for dimensions). The cables and terminals need to be prepared by yourself or purchased from APsystems.

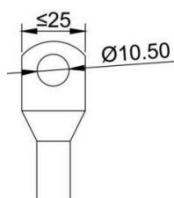

DC terminals

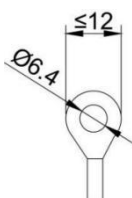

GRID terminals

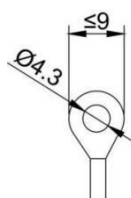

GEN/LOAD terminals

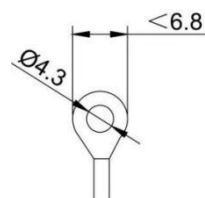

ATS terminals

#### DC cable:

Model	Wire Size	Cable(mm <sup>2</sup> )	Torque value
ELT-6	1 AWG	40	10Nm
ELT-8	1 AWG	40	10Nm
ELT-10	1/0AWG	60	10Nm
ELT-12	1/0AWG	60	10Nm

#### Grid cable:

Model	Wire Size	Cable(mm <sup>2</sup> )	Torque value
ELT-6/8/10/12	10 AWG	6	2.5Nm

#### GEN/LOAD cable:

Model	Wire Size	Cable(mm <sup>2</sup> )	Torque value
ELT-6/8/10/12	12 AWG	4	1.2Nm

#### Grid connection and backup load connection (Copper wires) (bypass):

Model	Wire Size	Cable(mm <sup>2</sup> )	Torque value
ELT-6/8/10/12	10 AWG	6	2.5Nm

## Remove the lower cover

When wiring, you need to remove the lower cover first, just unscrew the 2 locking screws at the bottom of the PCS.

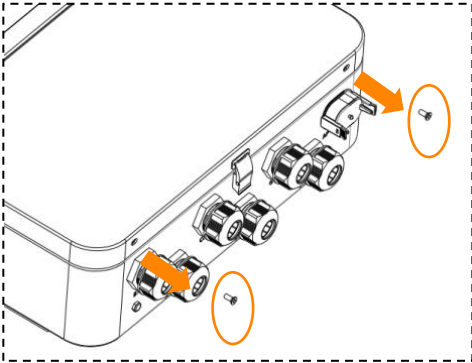

PCS has been installed with cable glands before delivery. If connection is required through pipe (prepare pipe yourself), remove cable glands on the casing first.

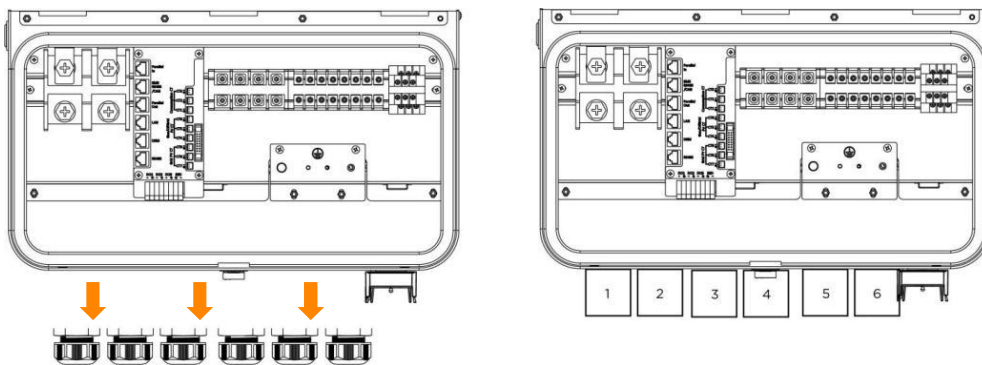

PIPE size: 1 1/2"

### NOTE:

The pipe must be waterproof.

### WARNING:

Do not drill holes in the casing at any location, otherwise we will not provide warranty.

### 3.5 Interface Layout Introduction

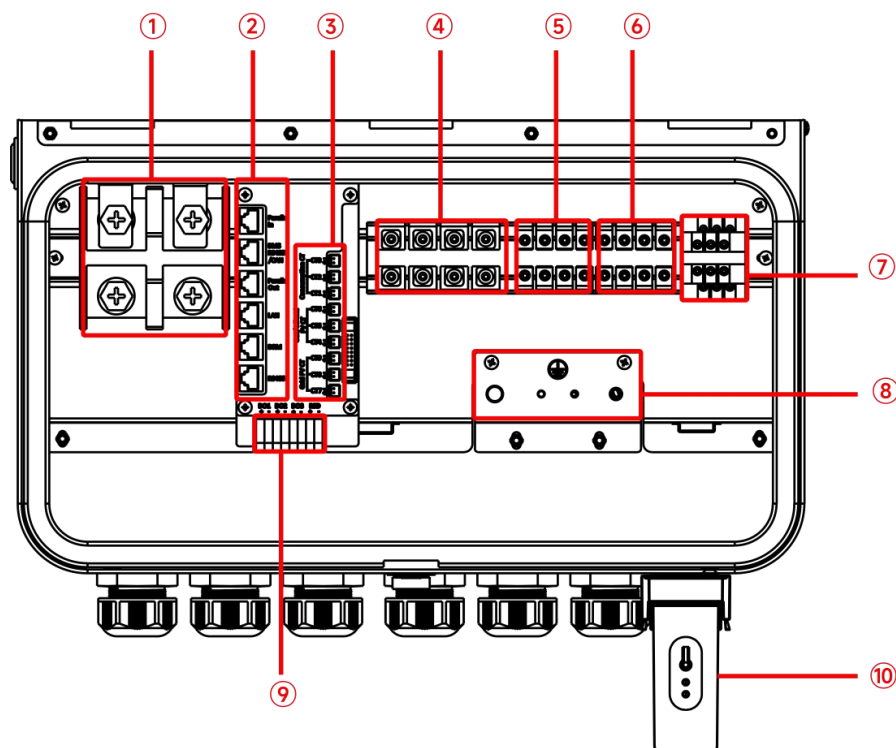

Object	Description
①	BAT+ /BAT- Terminals
②	Communication Terminals
③	CT Terminals
④	GRID Terminals
⑤	GEN Terminals
⑥	LOAD Terminals
⑦	ATS Terminals
⑧	Ground Terminals
⑨	DO1/DO2/DO3 Terminals/RSD Terminals
⑩	AP Dongle

### 3.6 Battery Connection

1. Connecting the battery with a suitable cable is important for safe and efficient operation of the system. To reduce the risk of injury, refer to Chapter 3.4 for recommended cables.
2. Use a suitable screwdriver to unscrew the bolts and fit the battery connectors in, then fasten the bolt by the screwdriver, make sure the bolts are tightened with torque of 10Nm in clockwise direction.
3. Make sure polarity at both the battery and PCS is correctly connected.

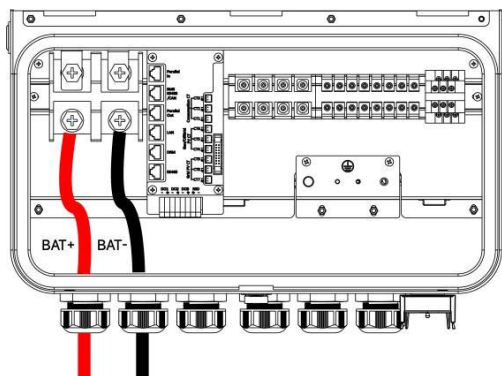

BAT+: Red or Orange  
 BAT-: Black

**NOTE:**

Before making the final DC connection or closing DC breaker/disconnect, be sure positive(+) must be connect to positive(+) and negative(-) must be connected to negative(-). Reverse polarity connection on battery will damage the PCS.

### 3.7 AC Wiring Connection

Use a suitable screwdriver to unscrew the bolts and fit the AC connectors in, then fasten the bolt by the screwdriver, make sure the bolts are tightened in clockwise direction. GRID terminals torque is 2.5Nm, GEN/LOAD terminals torque is 1.2Nm. Please refer to Chapter 3.4 for recommended cables.

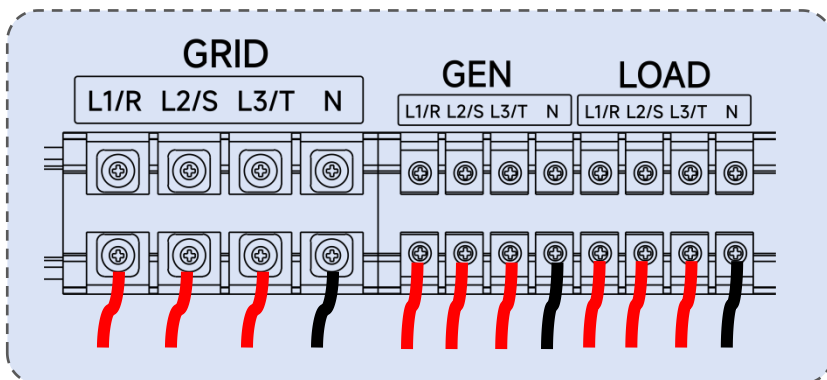

**NOTE:**

Do not loosen the screw to the end when removing wires, otherwise the terminal may be damaged. Make sure to connect the live wire to L1/L2/L3, connect the neutral wire to N, otherwise the precision of the CT will be affected.

### 3.8 Ground Wiring Connection

Use a suitable screwdriver to unscrew the bolts and fit the Ground connectors in, then fasten the bolt by the screwdriver, make sure the bolts are tightened in clockwise direction. Ground terminals torque is 2.5Nm for GRID, Ground terminals torque is 1.2Nm for GEN/LOAD.

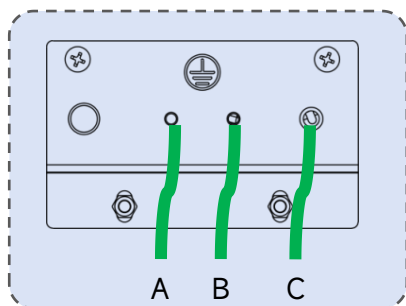

- A: For GEN AC connection
- B: For LOAD AC connection
- C: For GRID AC connection

### 3.9 Communication Connection

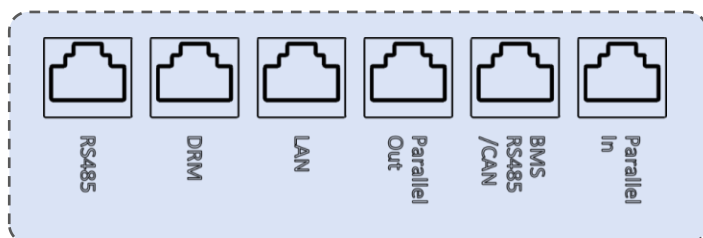

- Parallel In: Parallel communication port (CAN interface).
- BMS RS485/CAN: For battery communication.
- Parallel Out: Parallel communication port (CAN interface).

### 3.10 DO Connection

The PCS has integrated a multiple-function dry contact (DO1, DO2 and DO3). The DO can be set to one of the functions as follows, Generator Control and Load Control. For more information, please contact APstorage technical support team.

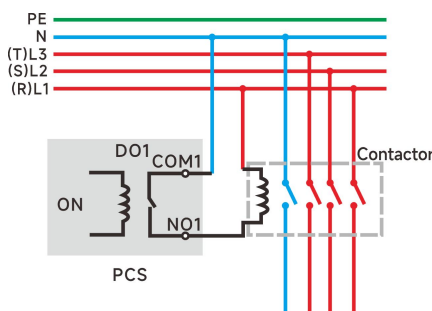
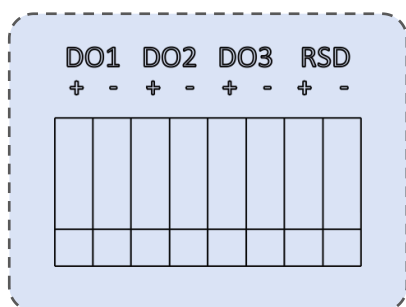

DO1/2/3-Load Control

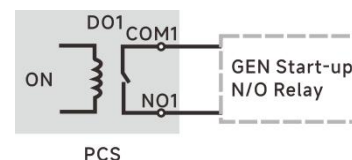

DO1-Generator Control

(DO1 can be used for load control if the generator is not used)

RSD(Rapid Shutdown Device): which can be used to quickly shut down the APstorage system.

### 3.11 CT Connection

There is a symbol (arrow) or label on the surface of CTs that indicates the correct mechanical orientation of the CT on the conductor under measurement. Please identify the arrow or label before installing the CT.

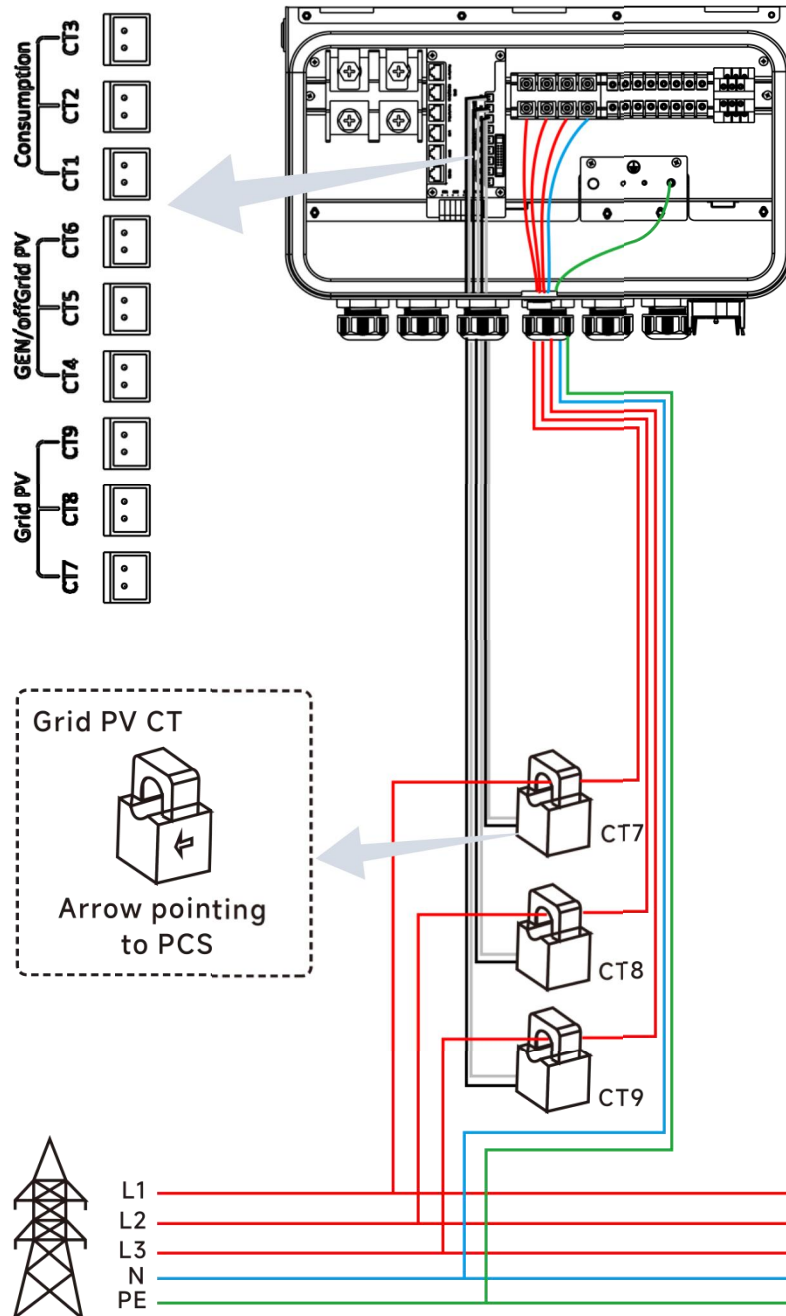

Grid PV CT wiring is shown in the diagram, please refer to this diagram for other CT wiring.

### 3.12 AP Dongle

AP Dongle is an intelligent communication expansion module used in conjunction with PCS to achieve wireless communication between PCS and the management system through WLAN and Bluetooth.



### 3.13 ATS Wiring Connection

According to local installation requirements, off grid neutral can be grounded internally or externally.

Connect the ATS cables to the PCS through the COM cable gland. As shown, connect wire L and N to terminal Block. Please refer to Chapter 3.4 for recommended cables.

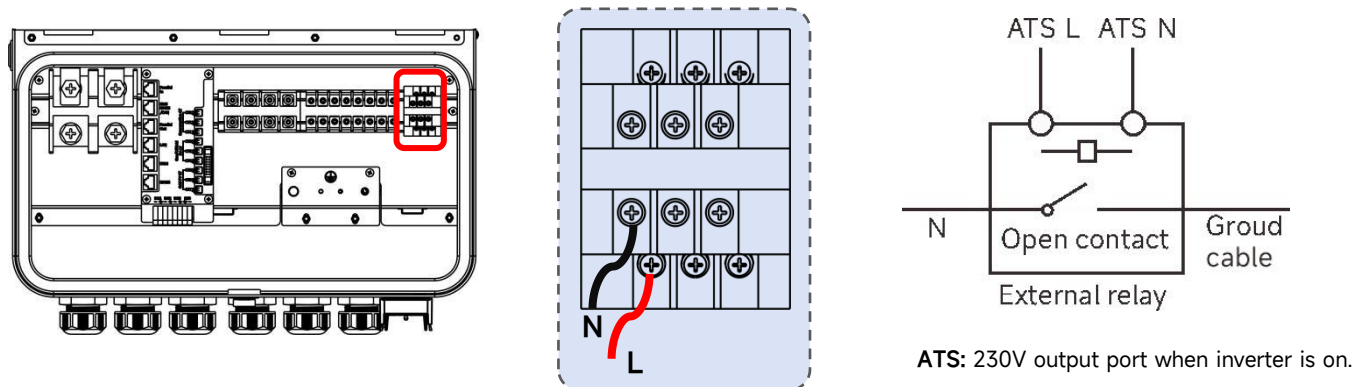

**NOTE:**

The ATS port is established based on mandatory external grounding requirements in certain countries, and users should choose whether to use it according to local requirements.

### 3.14 Wiring System for PCS

This diagram is an example for an application that neutral connects with the PE in a distribution box. For countries such as Australia, New Zealand, South Africa, etc., please follow local wiring regulations!

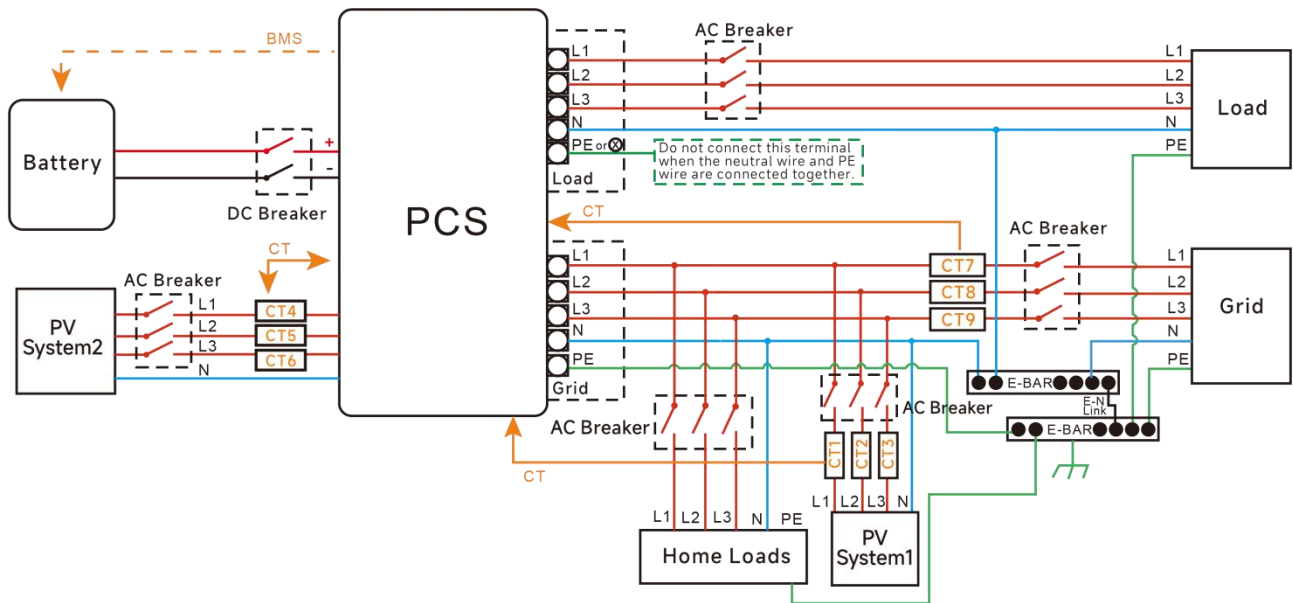

When the inverter is working in backup mode, neutral and PE on the backup side are connected via the internal relay. Also, this internal relay will be open when the inverter is working in grid tied mode.

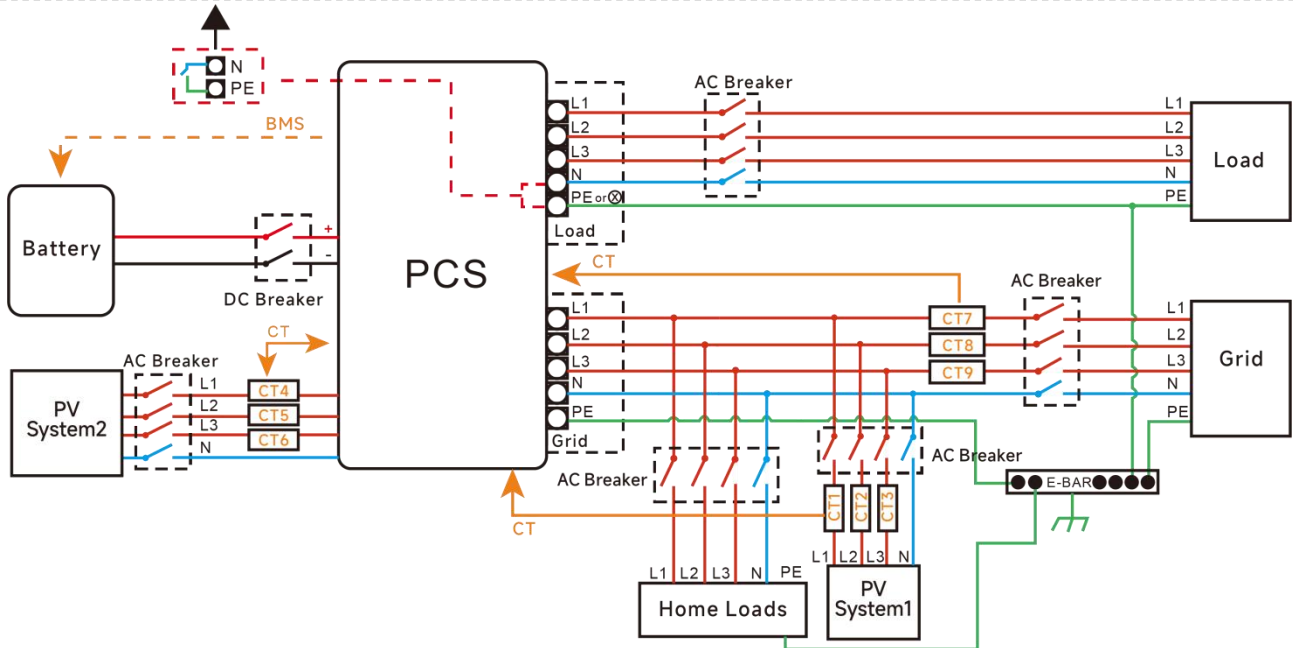

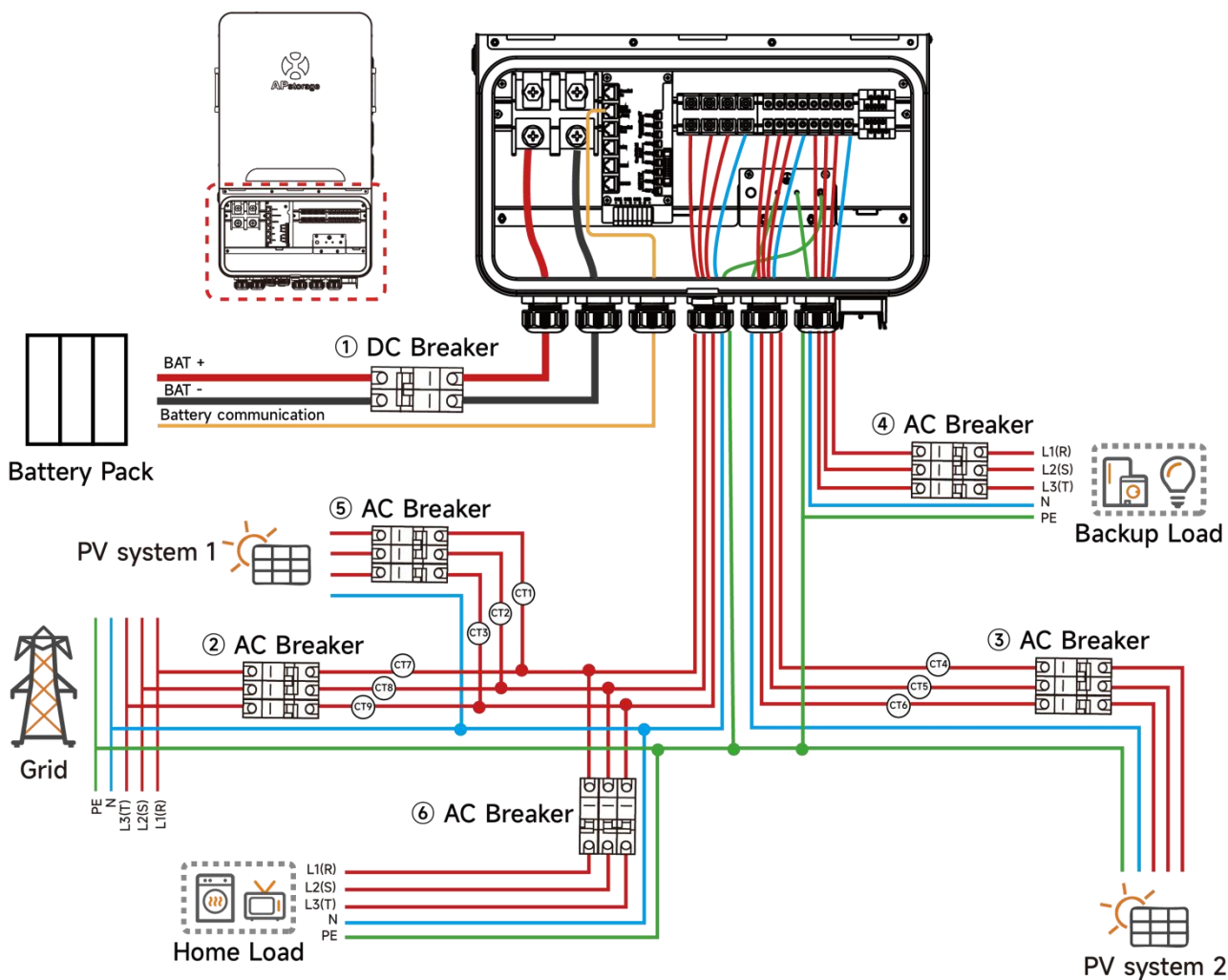

**① DC Breaker for battery**

- ELT-6: 200A DC breaker
- ELT-8: 250A DC breaker
- ELT-10: 300A DC breaker
- ELT-12:300A DC breaker

**② AC Breaker for Grid**

- ELT-6: 63A AC breaker
- ELT-8: 63A AC breaker
- ELT-10: 63A AC breaker
- ELT-12: 63A AC breaker

**③ AC Breaker for PV system 2**

- ELT-6: 32A AC breaker
- ELT-8: 32A AC breaker
- ELT-10: 32A AC breaker
- ELT-12: 32A AC breaker

**④ AC Breaker for Load**

- ELT-6: 32A AC breaker
- ELT-8: 32A AC breaker
- ELT-10: 32A AC breaker
- ELT-12: 32A AC breaker

**⑤ AC Breaker for PV system 1**

Depends on PV system 1

**⑥ AC Breaker for home load**

Depends on household loads

**NOTE:**

After having completed the wiring, the nuts of the cable gland must be tightened.

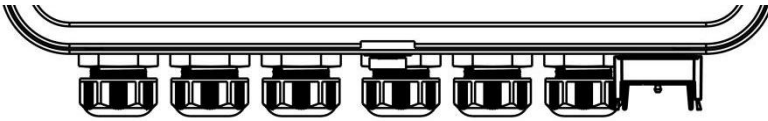
**NOTE:**

When there are two or more cables passing through the same gland, please use sealing putty to seal the gaps between the cables and the gland to prevent moisture from entering (prepare sealing putty yourself).

**Install the Lower Cover**

Complete wiring, screw the two screws back.

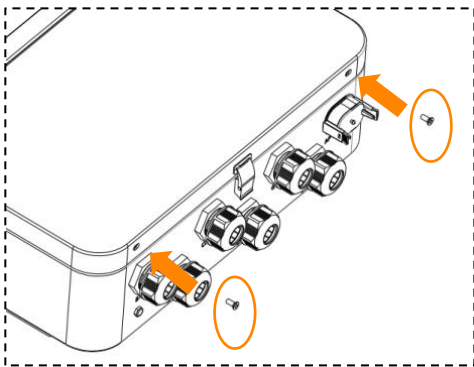

## 3.15 PCS Operation Procedures

### 3.15.1 Check all Below Steps Before Starting PCS

- ① Make sure the PCS is properly mounted to the wall.
- ③ Make sure all the DC wirings and AC wirings are completed.
- ④ Make sure the CT is connected properly.
- ⑤ Make sure the battery is connected properly.
- ⑥ Make sure all grounded busbar are connected property.
- ⑦ Make sure the PV system is connected properly.
- ⑧ Make sure the loads and critical loads are connected property, and the critical loads rating is within nominal rating range.

### 3.15.2 Power ON

Once the unit has been properly installed and the batteries are connected well, turn on the Battery DC Breaker, Grid AC Breaker, PV AC Breaker and Load AC Breaker, then turn on the batteries and press the on/ off button to power the system.

### 3.15.3 Check the system

Please refer to chapter 5.3.1 to check the system.

### 3.15.4 Power Off

Press the on/off button, turn off the Battery DC Breaker, Grid AC Breaker, PV AC Breaker and Load AC Breaker to power the system, then turn off the batteries.

#### **WARNING:**

Installation must be performed with care. Before making the final DC connection or closing DC breaker/disconnect, be sure positive(+) must be connect to positive(+) and negative(-) must be connected to negative(-). Reverse polarity connection on battery will damage the inverter.

#### **WARNING:**

The installer is responsible for providing overcurrent protection.To reduce the risk of fire, install a circuit breaker or overcurrent device on both positive(+) and negative(-) conductors to protect the system.

## 4. Off-Grid AC Coupling Installation

### 4.1 Frequency Shift Power Control

#### Functional Overview

If the PV inverter is connected to the GEN side of the PCS in the system, the PCS must be able to limit its output power. This limitation is necessary when the battery of the PCS is fully charged and the available power of the photovoltaic system exceeds the power demand of the connected load. In order to prevent the battery from overcharging, the PCS uses the measured the photovoltaic power and the requested charging power from battery to adjust the frequency of the microgrid, and the photovoltaic inverter adjusts the output power by detecting the change of the frequency of the microgrid.

The Frequency shift power control is enabled by default on PCS. At the same time, it is necessary to ensure that the PV System 2 is correctly connected to the Production CTs, the overfrequency load reduction function is enabled in PV system2, and is set according to the APstorage over-frequency load reduction parameter setting table.

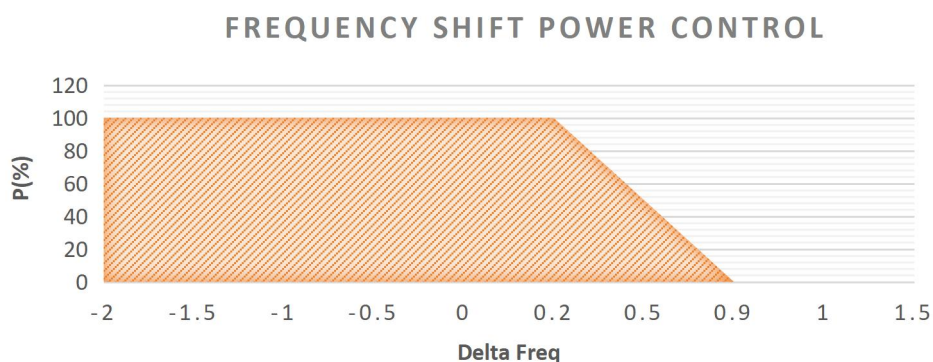

Example PV Inverter Function showing Power vs Delta Frequency

In the graph above, the horizontal axis is variation of the frequency, 0 is the rated frequency. The vertical axis represents the percentage of the current power to the rated power. The photovoltaic power changes with the microgrid frequency controlled by the PCS.

#### NOTE:

The frequency change curve shown in above figure is only for display purposes. The specific parameters of the photovoltaic inverter and PCS are set according to the local certification standards and APstorage over-frequency load reduction parameter setting table.

## 4.2 PV System to APstorage Pairing

1. Determine the maximum single load power rating (kW) to be backed up and select the absolute minimum number of PCS units.
2. Calculate the required energy storage capacity (kWh) based on the backup load estimate for the user defined time period, capacity and the minimum number of batteries required.
3. Calculate the maximum power (PV module 2) of the photovoltaic system connected to the PCS in Table 1.

Note the number is different if the PV inverter has Frequency Curtailment and/or not.

If the total power of the photovoltaic system is greater than the maximum power, the excess power (PV System1) is connected to the grid side.

**Table 1: The maximum power of the photovoltaic system for storage system backup**

ELT-12 units 1unit per 12kWac	Battery power(kWac)	Max PV system power in System 2 with Frequency Shifting (kWac)
1	≤15	Battery power
1	≥15	15

ELT-12 units 1unit per 12kWac	Battery power(kWac)	Max PV system power in System 2 with Frequency Shifting (kWac)
1	≤12	Battery power
1	≥12	12

Two calculation examples are given below for reference:

Step 1: Figure out Battery Max Charge Power.

Step 2: Figure out PCS Charge Power

Step 3: Take the smaller number

Step 4: Multiply by 1.25 (If using Frequency Power Control)

**Table 2: Examples Calculation of Off-grid Solar**

Examples Calculation of Off-grid Solar	
1 ELT-12+1 APbattery-51.2V/6.5kWh  1. Battery Power = 5kW 2. ELS Power =12kW 3. Battery Power is smaller than PCS Power 4. Off-grid PV power is 5kW	1 ELT-12+4 APbattery-51.2V/6.5kWh  1. Battery Power = 20kW 2. ELS Power = 12kW 3. PCS Power is smaller than Battery Power 4. Off-grid PV power is 12kW * 1.25 = 15kW

## 5. User Interface

Professional and certified Installer can commission, monitor and maintain the APstorage solution and performance via the EMA Manager APP. Please search for the APP in APP Store or Google Play, or use mobile browser to scan the QR codes to download the APP. (EMA App is for end-users, EMA Manager is for installers). You can also click on the link below to download the APP: <http://q-r.to/1OrC>

### 5.1 Configure APstorage with EMA Manager

The APstorage PCS has been designed with local connection and management functionality. You can access this local functionality through EMA Manager. Click “Local access” to enter this function.

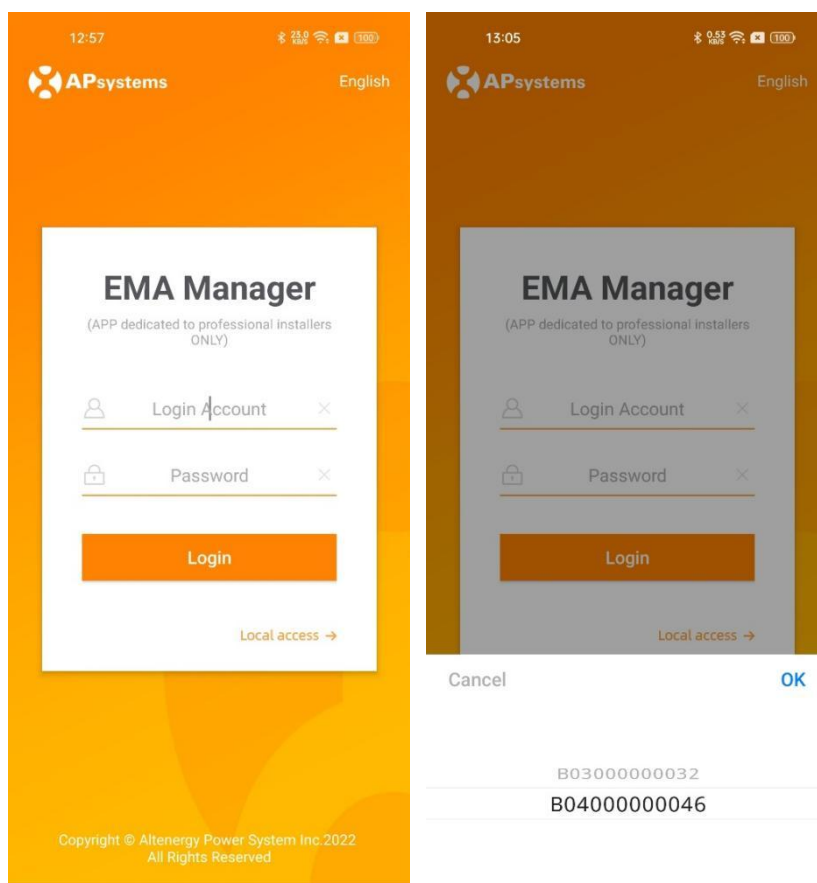

You will be noticed if your smartphone or tablet is not enable Bluetooth or is too far away from the APstorage PCS.

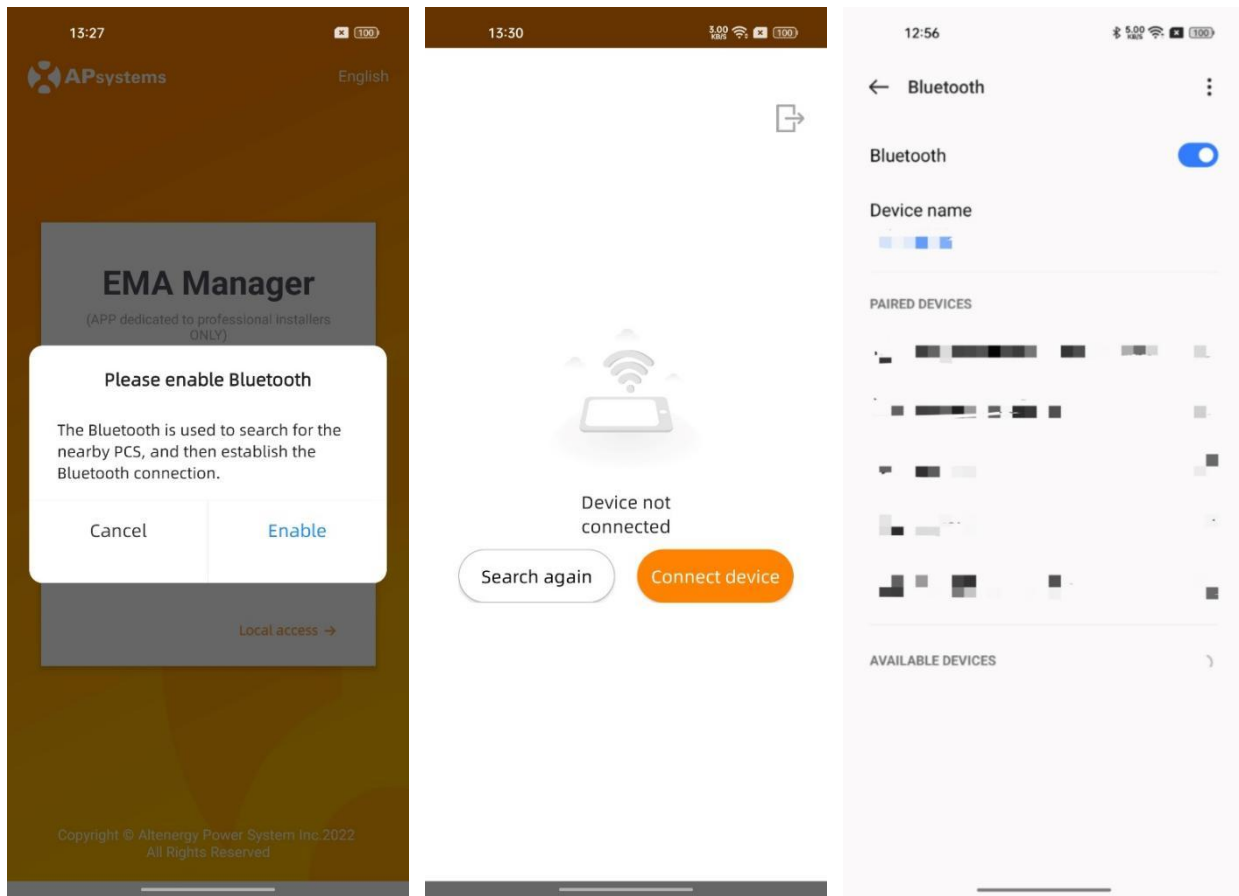

-Step 1: Open Bluetooth setting in your smartphone, and enable Bluetooth.

-Step 2: Open EMA Manager.

-Step 3: Click "Local access"

You can use this APP to connect the APstorage PCS to the router via Wlan. (Please refer to chapter 5.3.3.1)

## 5.2 Home Page

5.2.1 After selecting the ID of APstorage PCS, you can access the homepage. If you have multiple APstorage PCS, you can switch by clicking on the dropdown menu.

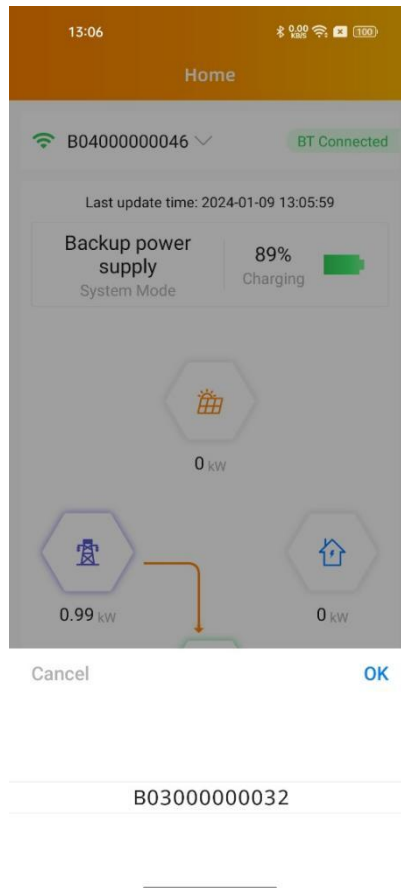

5.2.2 You can view the system ID, charge and discharge status, real-time power, SOC, today's charged energy, total charged energy since installed, and CO<sub>2</sub> reduction.

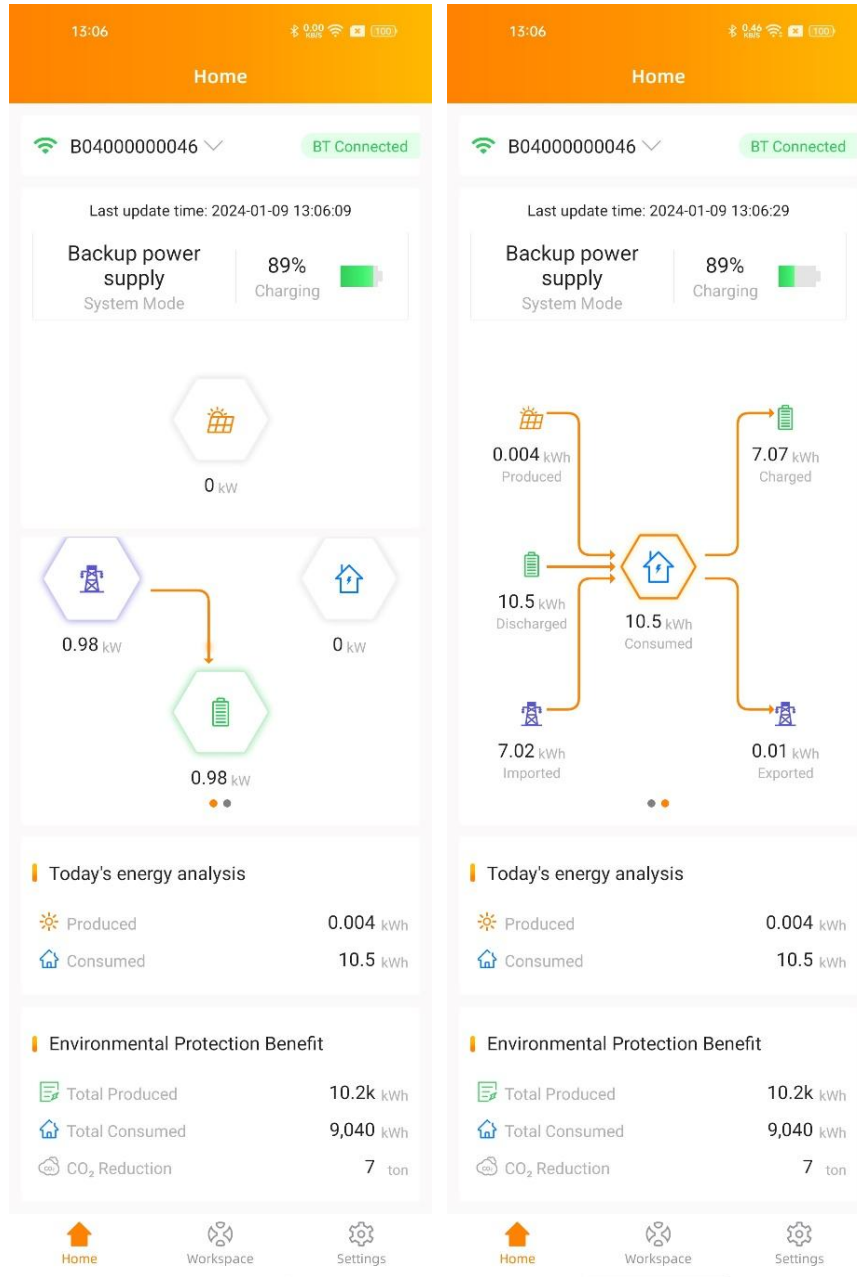

## 5.3 Workbench

The workbench displays the latest communication time, and currently supported function catalog. Click the corresponding button to enter the function page.

### 5.3.1 Automatic System Check

Enter the Automatic System Check interface, you can check the PCS information. If there is an alarm, you can click to view the detailed information.

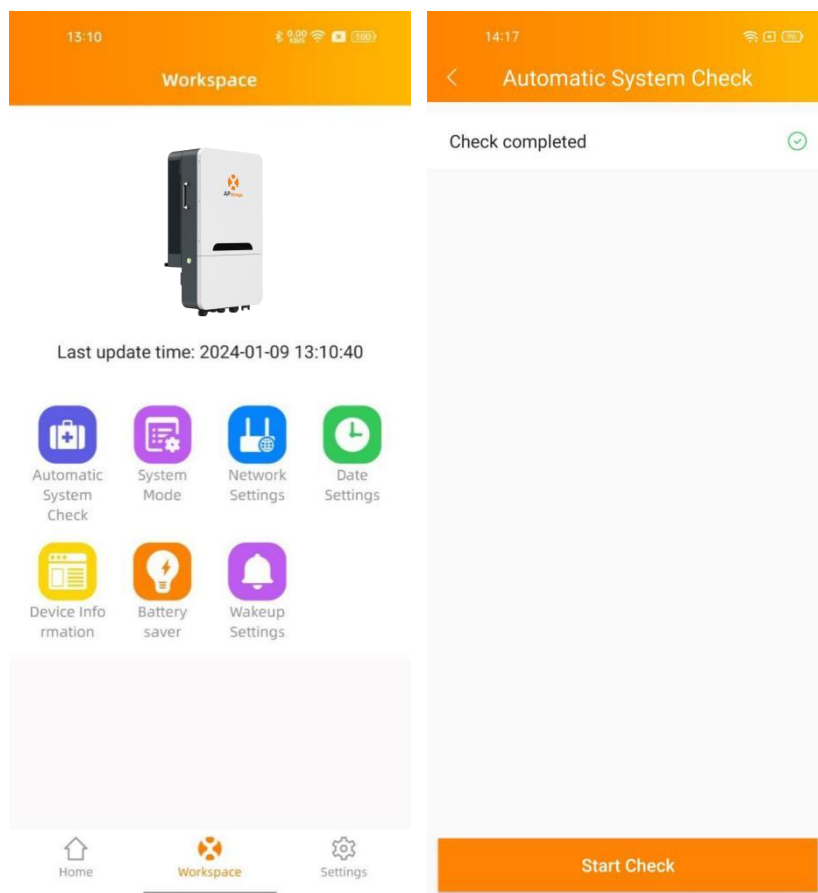

### 5.3.2 System Mode

The system mode of the APstorage PCS includes backup power supply mode, residual power Self Consumption mode, advanced mode and Peak-Shaving mode. If you need to set the system working mode, please select the corresponding working mode and set the parameters, and then click "OK".

**Backup power supply mode:**

Emergency power supply (EPS) mode, the system charge when grid connected and discharge when off grid.

**Self-Consumption mode:**

APstorage charges when solar power is produced more than home requires, and the power is used for household appliances when your home requires more power than your solar system can provide.

**Advanced mode:**

Discharge during peak time, charge during off-peak time.

**Peak-Shaving mode:**

Input peak-shaving power,when the power of load exceeds the set value of peak-shaving power, the excess power is provided by PCS.

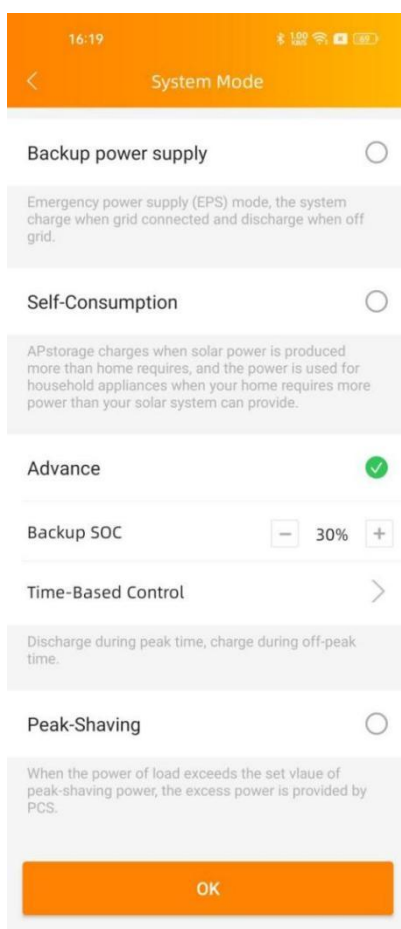

### 5.3.2.1 Time-Based Control

Click “Time-Based Control”, you can view the list of peak times and off-peak times currently set. You can edit the time ranges by clicking on it. Click on the "Add" button to select the peak time or off-peak time to be added.

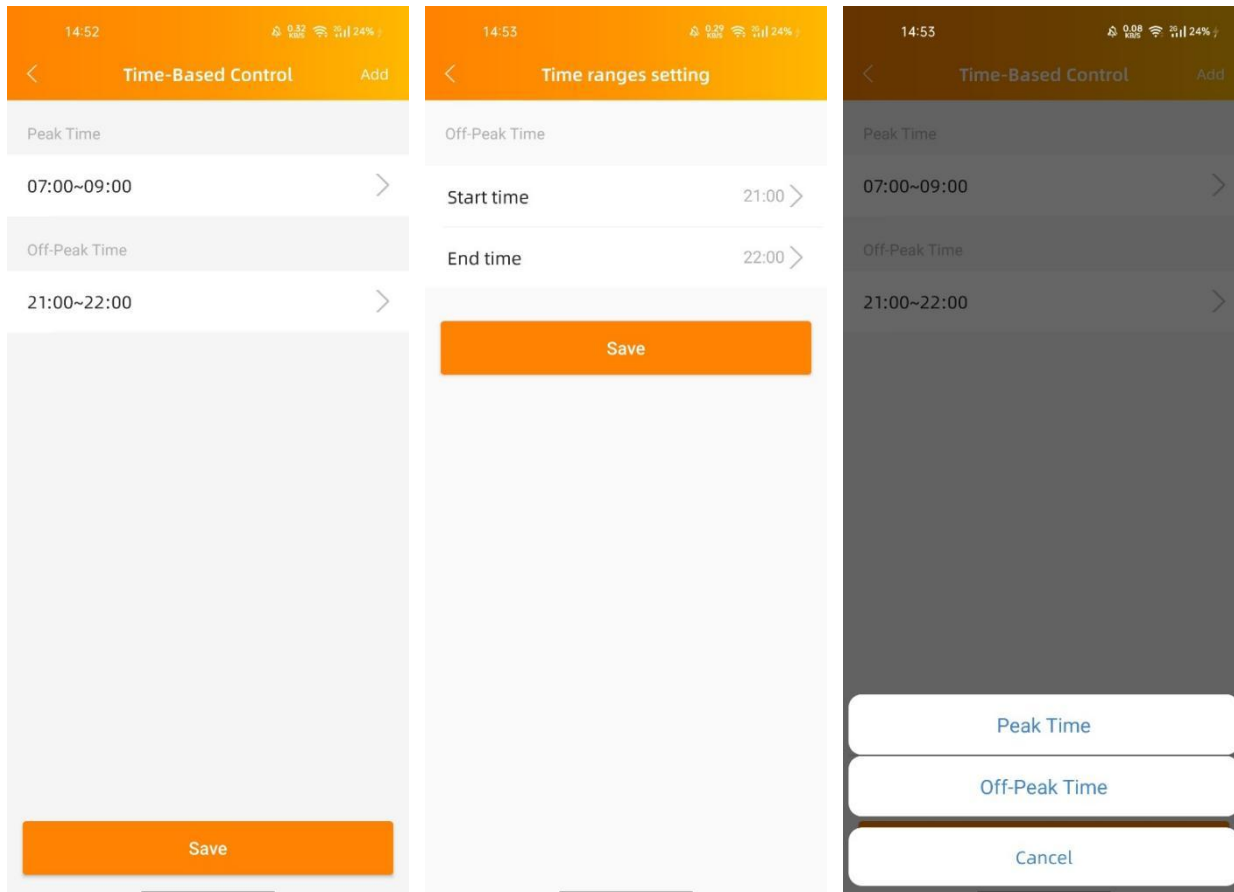

### 5.3.3 Network Setting

Click the button to enter the WLAN Settings page.

#### 5.3.3.1 WLAN Settings

This interface will display the WLAN connection status of the APstorage PCS. Scroll down the screen and the available SSID will be displayed. Click SSID, and enter the password.

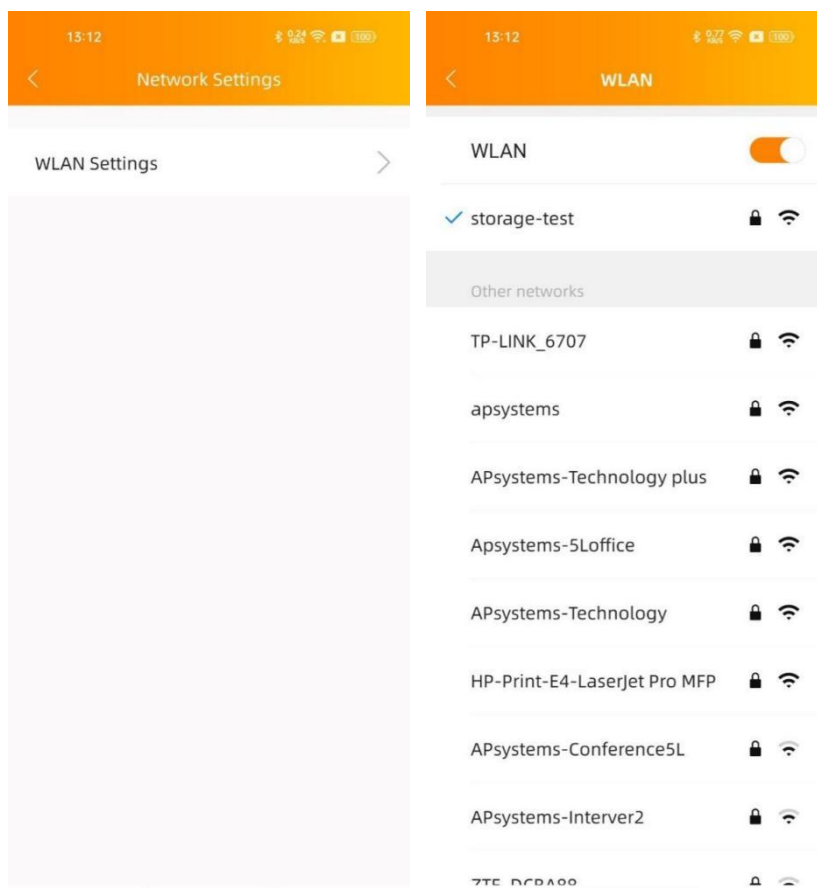

### 5.3.4 Data Settings

After entering this page, the time will be displayed on the right. Click on the date, time to modify.

### 5.3.5 Device Information

The device information page displays the device ID, device type, PCS number, battery capacity, DCM version number, Module version number , wireless network MAC, currently connected router SSID, IP address.

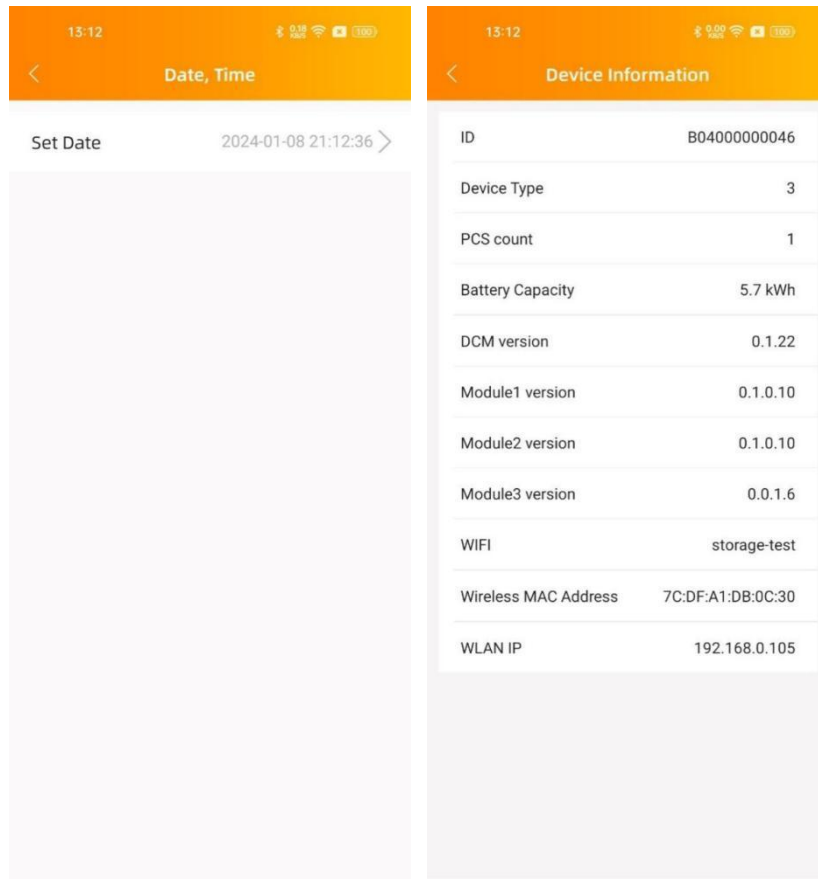

### 5.3.6 Battery saver

Enter this page, you can enable the "battery saver" function. After enabling the "battery saver" function, if APstorage doesn't charge or discharge for an hour, it will go to sleep.

### 5.3.7 Wake up Settings

Wakeup Settings is used for system wake-up related settings.

When system enters into sleeping mode, you can wake it up by clicking on "Wake Up Immediately".

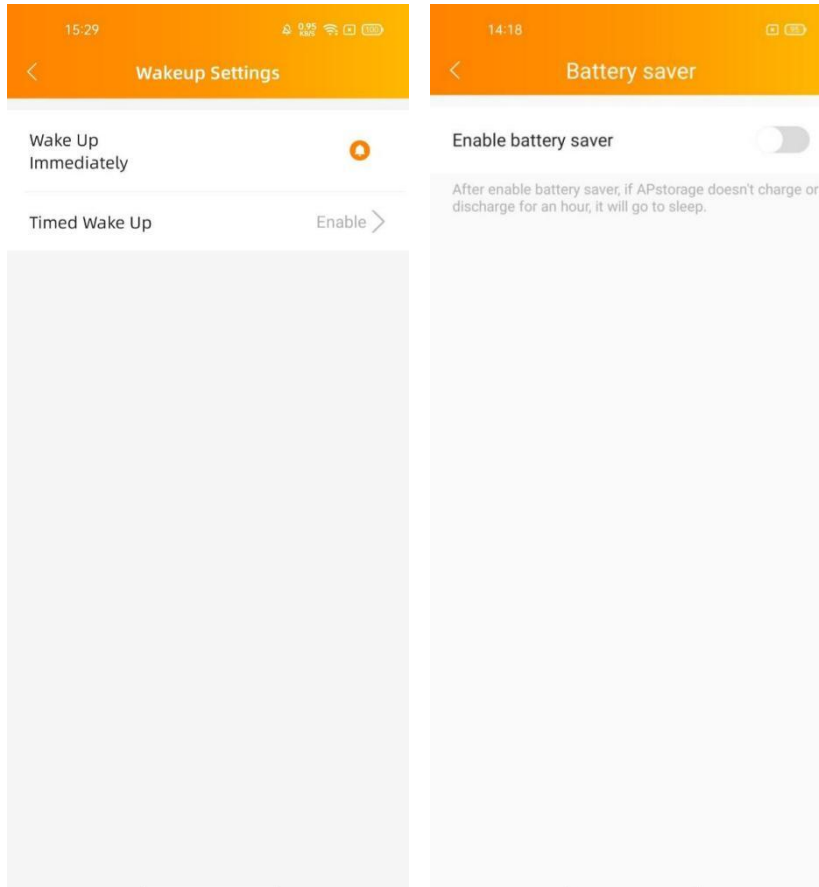

### 5.3.7.1 Timed Wake Up

On this page, you can set the wake-up time period and interval, the system will wake up at the set time interval within the set time period.

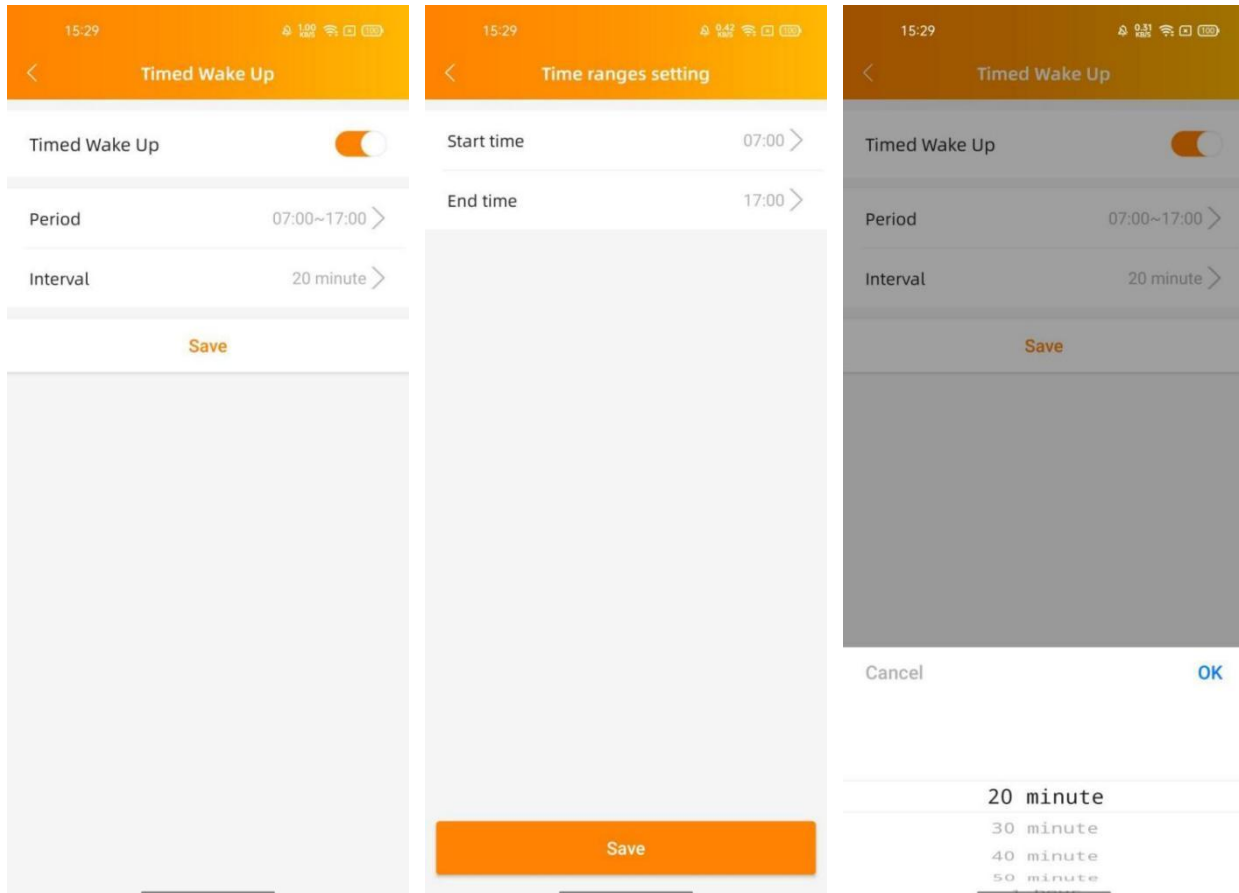

## 5.4 Settings

Select "Language" to set the APP language, and "About" to view the APP introduction.

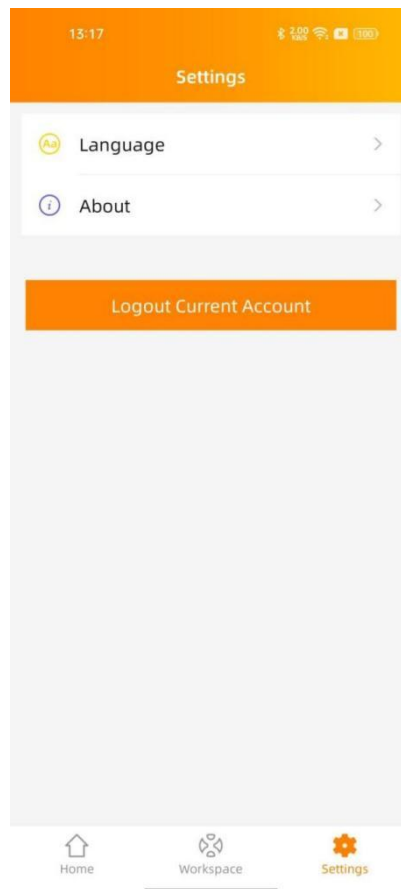

## 6. Technical Data

Model	ELT-6	ELT-8	ELT-10	ELT-11
Region	EMEA			
<b>General Specifications</b>				
Dimensions W/H/D	818×474×275mm			
Weight	45.75kg			
Maximum Efficiency	96.5%			
Operating Ambient Temperature	-25°C-65°C, >45°C derating			
Storage Temperature Range	-40°C-85°C			
Environment category	Outdoor			
Ingress Protection	IP65			
Pollution Degree Classification	PD2			
Relative Humidity	4%-100%			
Protective Class	Class I			
Over Voltage Category	III (MAINS), II (Battery)			
Cooling	Smart cooling			
Permissible Altitude (m)	≤2000m			
Communication Ports	Ethernet/RS485/CAN			
Wi-Fi Frequency Range	2412MHz - 2472MHz			
Wi-Fi Maximum Power (EIRP)	17.67 dBm			
Bluetooth Frequency Range	2402MHz - 2480MHz			
Bluetooth Maximum Power (EIRP)	8.57 dBm			
Grid Regulation	VDE-AR-N 4105, EN 50549-1, EN 50549-10			
Safety	EN IEC 62477-1			
EMC	EN IEC 61000-6-1, EN IEC 61000-6-2, EN IEC 61000-6-3, EN IEC 61000-6-4, EN 55011, EN 62920			
Warranty	10 years			
<b>Battery Input /Output Data</b>				
DC Battery Input Voltage	40.0-60.0VDC			
Charging Strategy for Li-Ion Battery	Self-adaption to BMS			
Charging Curve	3 Stages / Equalization			
Max Continuous Charge Current	135A	180A	225A	240A
Max Continuous Discharge Current	135A	180A	225A	240A
<b>AC Input/Output Data (On-grid)</b>				
Max. Continuous Output Power	6000VA	8000VA	10000VA	12000VA
Max. Continuous Output Current	8.7A	11.6A	14.5A	17.4A
Max. Continuous Current From	17.4A	23.2A	29A	34.8A
Nominal Output Voltage	400V, 3L/N/PE			
EPS Switch Time	10ms			
Nominal Output Frequency/Range	50Hz/47.5Hz-51.5Hz			
Output Power Factor	>0.99 (Adjustable from 0.8 leading to 0.8 lagging)			
THD	<3%			
Grid Connection	Three-phase			
Max. Continuous Output Power	400V, 3L/N/PE			

**AC Output Data (Backup)**

Max. Output Apparent Power	6000VA	8000VA	10000VA	12000VA
Peak Output Apparent Power	9000VA(10s)	12000VA(10s)	15000VA(10s)	18000VA(10s)
Max. Output Current	8.7A	11.6A	14.5A	17.4A
Nominal Output Voltage	400V, 3L/N/PE			
Nominal Output Frequency	50Hz			

**AC Input Data(Off-Grid Input/Gen)**

Max. Input Apparent Power	6000VA	8000VA	10000VA	12000VA
Peak Input Apparent Power	9000VA(10s)	12000VA(10s)	15000VA(10s)	18000VA(10s)
Max.Input Current	8.7A	11.6A	14.5A	17.4A
Nominal Input Voltage	400V, 3L/N/PE			
Nominal Input Frequency	50Hz			

© All Rights Reserved

Specifications subject to change without notice please ensure you are using the most recent update found at web : [emea.APsystems.com](http://emea.APsystems.com)

## EU DECLARATION OF CONFORMITY

(No. 20240522)

We, **ALTENERGY POWER SYSTEM INC.**

Of

**Building 2, No. 522, Yatai Road, Nanhu District, Jiaxing City, Zhejiang 314050, China**

declare under our sole responsibility that the product

Product Description: **Power Conversion System**

Model No.: **ELT-12, ELT-10, ELT-8, ELT-6**

to which this declaration relates, is in conformity with the following standards and/or other normative documents.

Safety	EN 62477-1:2012; EN 62477-1:2012/A11:2014 EN 62477-1:2012/A1:2017; EN 62477-1:2012/A12:2021
Health	EN IEC 62311:2020; EN 50665:2017
EMC	EN 55011:2016/A2:2021; EN 62920:2017/A1:2021; EN IEC 61000-6-1:2019; EN IEC 61000-6-2:2019; EN IEC 61000-6-3:2021; EN IEC 61000-6-4:2019; EN IEC 61000-3-2:2019+A1:2021; EN 61000-3-3:2013/A2:2021; EN 61000-3-12:2011; EN 301 489-1 V2.2.3(2019-11); EN 301 489-17 V3.2.4(2020-09)
Radio	EN 300 328 V2.2.2(2019-07)

We hereby declare that the above named product is in conformity with to all the essential requirements of Radio Equipment Directive 2014/53/EU (RED).



Title: Director

Address: Jiaxing, China

Date: 2024/05/24

English

## EU-KONFORMITÄTSERKLÄRUNG

(Nr. 20240522)

Wir, **ALTENERGY POWER SYSTEM INC.**

Von

**Gebäude 2, Nr. 522, Yatai Straße, Nanhu Bezirk, Jiaxing Stadt, Zhejiang 314050, China**

erklären unter unserer alleinigen Verantwortung, dass das Produkt

Produktbeschreibung: **Stromumwandlungssystem**

Modell: **ELT-12, ELT-10, ELT-8, ELT-6**

auf die sich diese Erklärung bezieht, ist die Übereinstimmung mit den folgenden Normen und/oder anderen normativen Dokumenten.

Safety	EN 62477-1:2012; EN 62477-1:2012/A11:2014 EN 62477-1:2012/A1:2017; EN 62477-1:2012/A12:2021
Health	EN IEC 62311:2020; EN 50665:2017
EMC	EN 55011:2016/A2:2021; EN 62920:2017/A1:2021; EN IEC 61000-6-1:2019; EN IEC 61000-6-2:2019; EN IEC 61000-6-3:2021; EN IEC 61000-6-4:2019; EN IEC 61000-3-2:2019+A1:2021; EN 61000-3-3:2013/A2:2021; EN 61000-3-12:2011; EN 301 489-1 V2.2.3(2019-11); EN 301 489-17 V3.2.4(2020-09)
Radio	EN 300 328 V2.2.2(2019-07)

Hiermit erklären wir, dass das oben genannte Produkt allen wesentlichen Anforderungen der Funkgeräterichtlinie 2014/53/EU (RED) entspricht.



Titel: Director

Adresse: Jiaxing, China

Datum: 2024/05/24

Deutsch

## European offices

### APsystems EMEA

Karspeldreef 8, 1101 CJ, Amsterdam, The Netherlands

Email: [info.emea@APsystems.com](mailto:info.emea@APsystems.com)

Web: [emea.APsystems.com](http://emea.APsystems.com)

### APsystems France

22 Avenue Lionel Terray 69330 Jonage, France

Mail: [info.emea@APsystems.com](mailto:info.emea@APsystems.com)

Web: [emea.APsystems.com](http://emea.APsystems.com)